

Our Products have cured by

Microwave Autoclave Won Appreciation Worldwide Due To Their Supreme Quality.

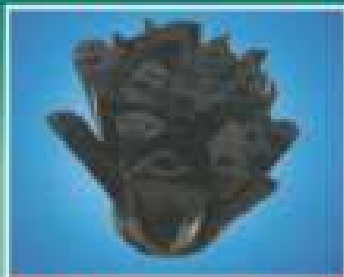

EPDM Rubber Profile



Building Rubber Profile



Glass Run Channels



Door Rubber Profiles



Container Rubber Seal Profile

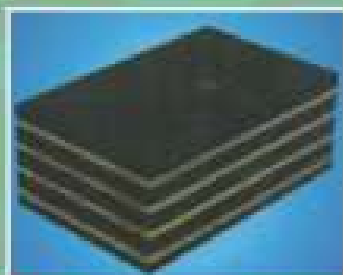

Bridge Bearing Pad



Compression Seal



Rubber Strip Seal For Bridges

We are Mfg. All Type of Extruded Rubber & Moulding Rubber Parts

- EPDM, Synthetic, Neoprene, Silicon, Natural Rubber Profiles
- Bus, Truck body Fitting Rubber
- Wind Shield Rubber Profiles
- Glass Run Channels (Flocked)
- Automotive Rubber Parts
- EPDM Rubber Gaskets
- Building Rubber Profiles
- Aluminium Section Rubber Profile
- Sponge Rubber/Rubber Cords
- Container Door Rubber Beading
- Electrical Panel Rubber Beading
- Metal To Rubber Bonding
- Rubber Strip Seal For Bridges
- Rubber Seals/Compression Seal
- Bridge Bearing Pad/ Slab Seal
- PVC, TPR & TPE Extrusions



Anil Gupta (Prop.) : + 91-9811132251, 9911132251, 9311132251

Phone: +91-129-2301227, 2211527,

Plot No.6, Gali No.6, Raghuveer Colony, Sector-2, Ballabgarh,
Faridabad-121004, Haryana, India.

Web: www.sairubbers.in, E-mail: sairubber909@gmail.com



SAI RUBBER

AN ISO 9001 : 2015 Certified Co.

Product Catalogue

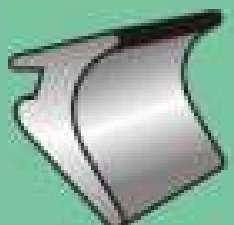
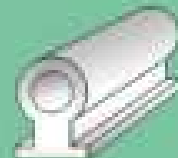
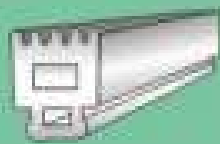
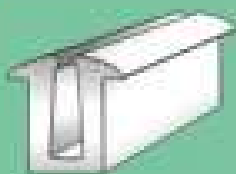
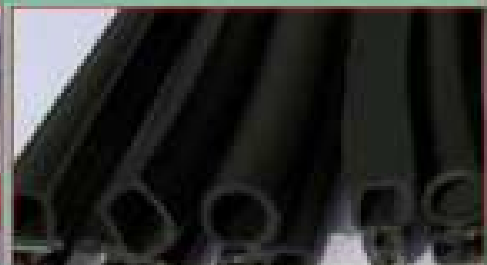
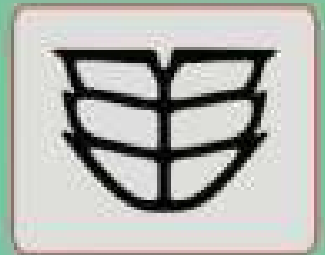
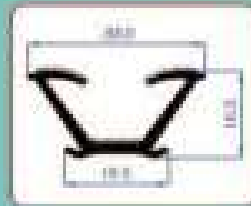
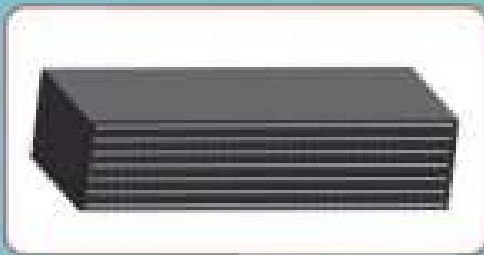



SAAROCIAL-881



Weight per Meter in Kg. 0.028

SAAROCIAL-882



Weight per Meter in Kg. 0.028

SAAROCIAL-883



Weight per Meter in Kg. 0.030

SAAROCIAL-884



Weight per Meter in Kg. 0.025

SAAROCIAL-885



Weight per Meter in Kg. 0.030

SAAROCIAL-886



Weight per Meter in Kg. 0.040

SAAROCIAL-887



Weight per Meter in Kg. 0.030

SAAROCIAL-888



Weight per Meter in Kg. 0.040

SAAROCIAL-889



Weight per Meter in Kg. 0.045

SAAROCIAL-879



Weight per Meter in Kg. 0.030

SAAROCIAL-871

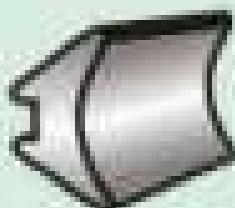

Weight per Meter in Kg. 0.030

SAAROCIAL-872



Weight per Meter in Kg. 0.100

SARACIAL-013



Weight per Meter in Kg. 0.048

SARACIAL-014



Weight per Meter in Kg. 0.050

SARACIAL-015



Weight per Meter in Kg. 0.050

SARACIAL-016



Weight per Meter in Kg. 0.048

SARACIAL-017



Weight per Meter in Kg. 0.073

SARACIAL-018



Weight per Meter in Kg. 0.040

SARACIAL-019



Weight per Meter in Kg. 0.068

SARACIAL-020



Weight per Meter in Kg. 0.070

SARACIAL-021



Weight per Meter in Kg. 0.055

SARACIAL-022



Weight per Meter in Kg. 0.075

SARACIAL-023

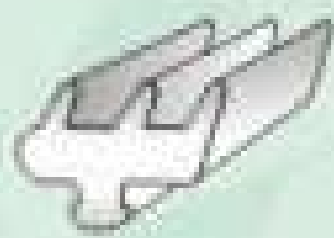

Weight per Meter in Kg. 0.097

SARACIAL-024



Weight per Meter in Kg. 0.075

SAIARCIAL-049



Weight per Meter in Kg.

SAIARCIAL-050



Weight per Meter in Kg. 0.045
Ø 5mm

SAIARCIAL-051



Weight per Meter in Kg. 0.032
Ø 4mm

SAIARCIAL-052



Weight per Meter in Kg. 0.000

SAIARCIAL-053



Weight per Meter in Kg. 0.000

SAIARCIAL-054



Weight per Meter in Kg. 0.000

SAIARCIAL-055

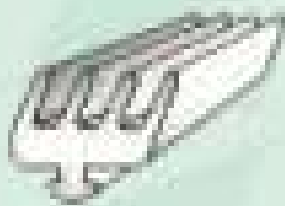

Weight per Meter in Kg. 0.110

SAIARCIAL-056

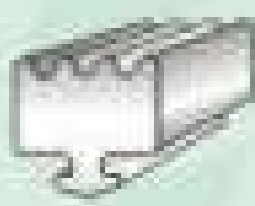

Weight per Meter in Kg. 0.000

SAIARCIAL-057

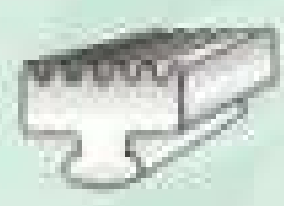

Weight per Meter in Kg. 0.040

SAIARCIAL-058

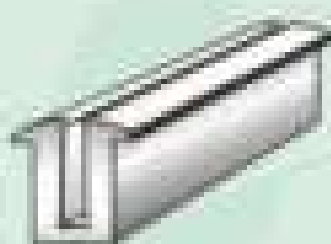

Weight per Meter in Kg.

SAIARCIAL-059



Weight per Meter in Kg.

SAIARCIAL-060



Weight per Meter in Kg.



SARACIAL-001



Weight per Meter in Kg _____

SARACIAL-002



Weight per Meter in Kg _____

SARACIAL-003



Weight per Meter in Kg _____

SARACIAL-004



Weight per Meter in Kg _____

SARACIAL-005



Weight per Meter in Kg _____

SARACIAL-006



Weight per Meter in Kg _____



SAAROCIAL-025



Weight per Meter in Kg. 3.050

SAAROCIAL-026



Weight per Meter in Kg. 3.060

SAAROCIAL-027



Weight per Meter in Kg. 3.080

SAAROCIAL-028



Weight per Meter in Kg. -----

SAAROCIAL-029



Weight per Meter in Kg. 3.040

SAAROCIAL-030



Weight per Meter in Kg. 3.040

SAAROCIAL-031



Weight per Meter in Kg. 3.070

SAAROCIAL-032

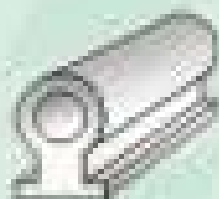

Weight per Meter in Kg. 3.040

SAAROCIAL-033



Weight per Meter in Kg. 3.020

SAAROCIAL-034



Weight per Meter in Kg. -----

SAAROCIAL-035



Weight per Meter in Kg. 3.200
(For 4 mm Glass)

SAAROCIAL-036

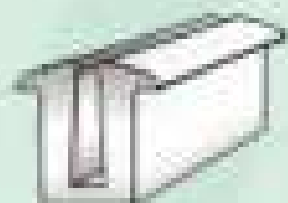

Weight per Meter in Kg. 3.180
(For 5 mm Glass)



SARACIAL-037



Weight per Meter in Kg. 0.170
(For 5 mm Glass)

SARACIAL-038

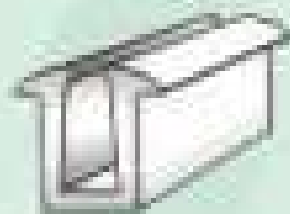

Weight per Meter in Kg. 0.160
(For 5 mm Glass)

SARACIAL-039

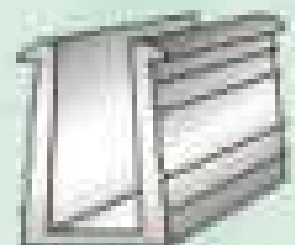

Weight per Meter in Kg. ———
(For 12 mm Glass)

SARACIAL-040



Weight per Meter in Kg. 0.120
(For 5 mm Glass)

SARACIAL-041

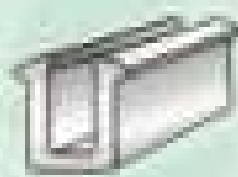

Weight per Meter in Kg. 0.095
(For 5 mm Glass)

SARACIAL-042

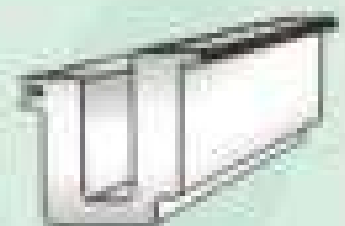

Weight per Meter in Kg. 0.300

SARACIAL-043



Weight per Meter in Kg. 0.040

SARACIAL-044



Weight per Meter in Kg. 0.050

SARACIAL-045



Weight per Meter in Kg. 0.100

SARACIAL-046



Weight per Meter in Kg. 0.075

SARACIAL-047



Weight per Meter in Kg. 0.075

SARACIAL-048



Weight per Meter in Kg. 0.075

Rubber Seal For Expansion Joints

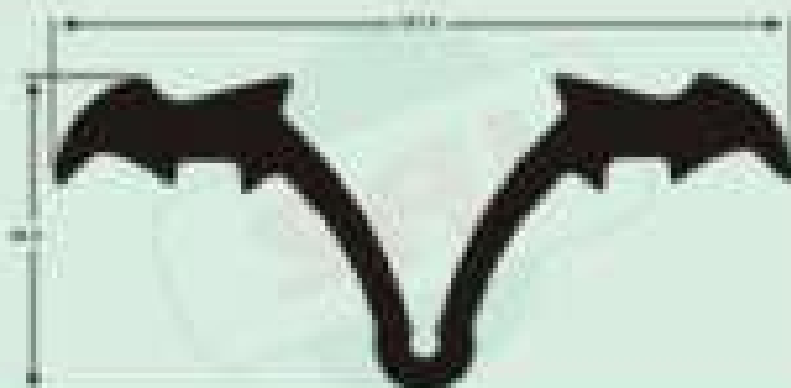
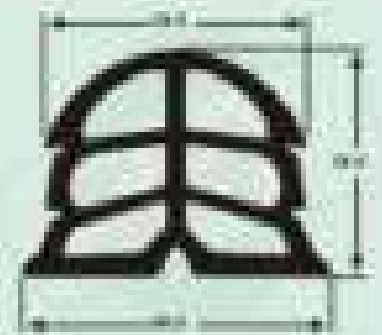
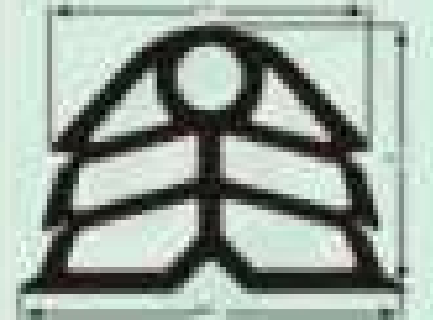
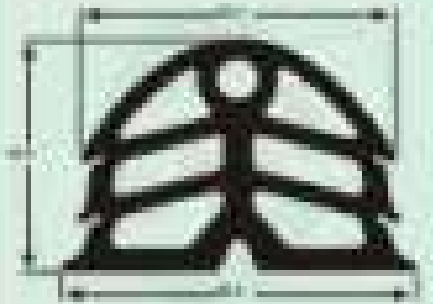
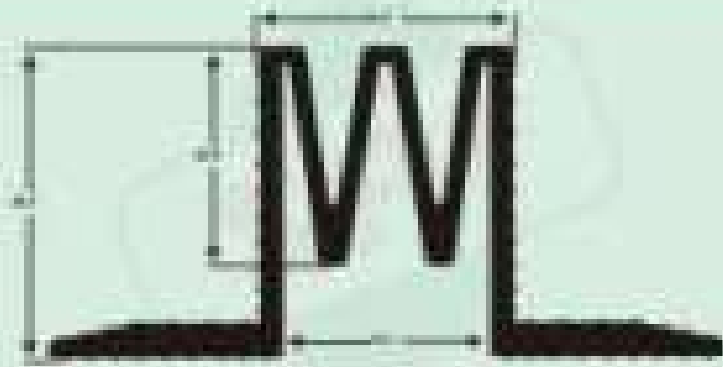

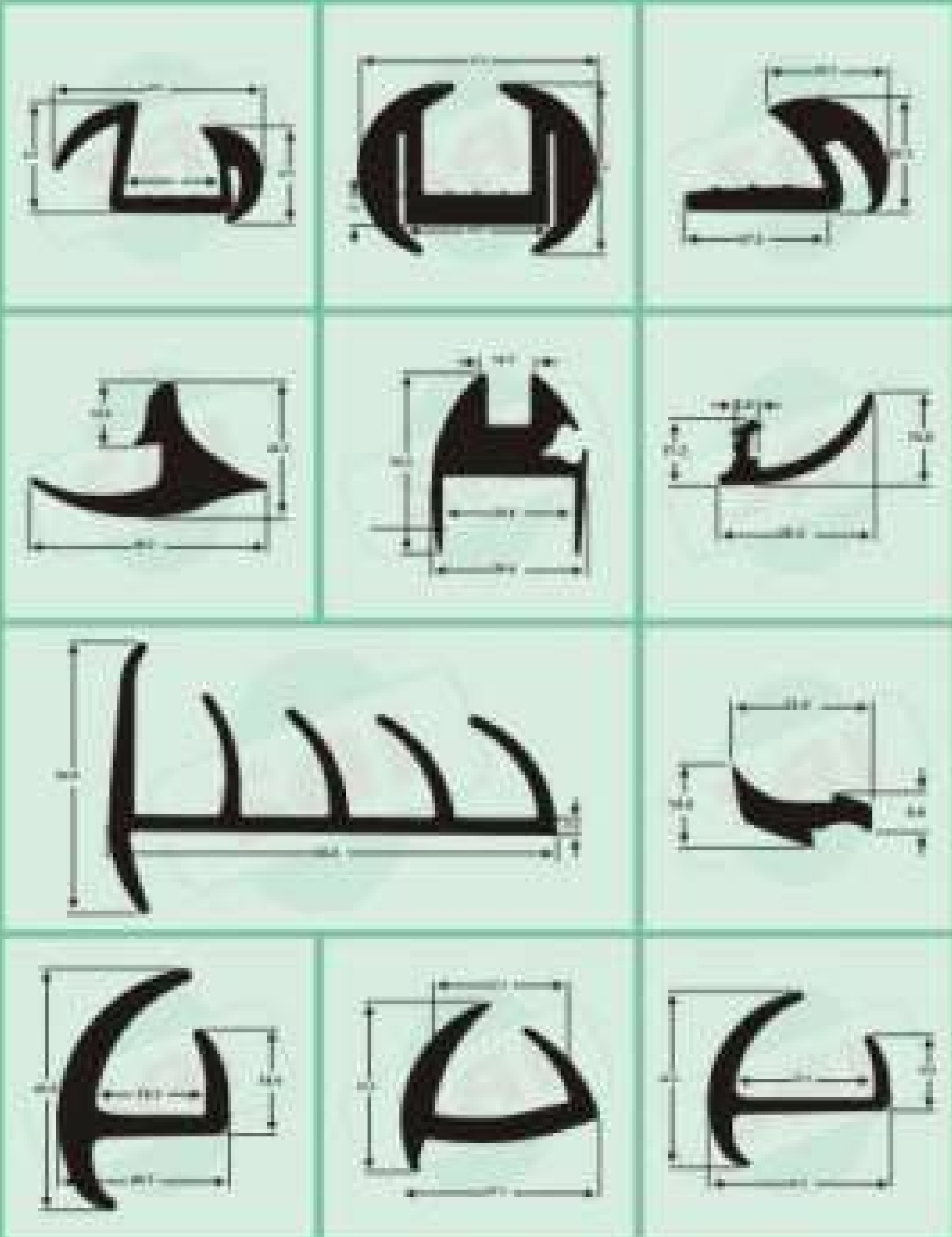

Bus Body Building Profiles

SAI

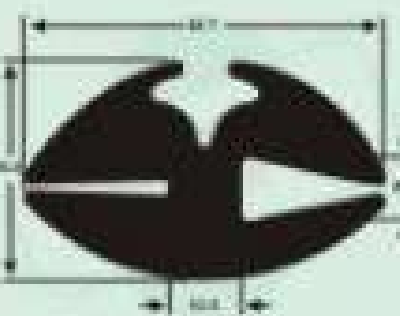
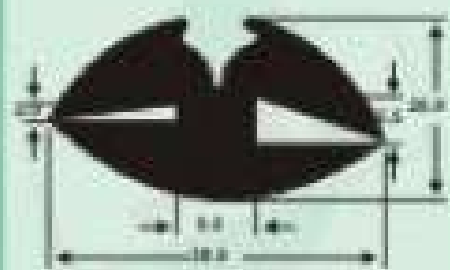
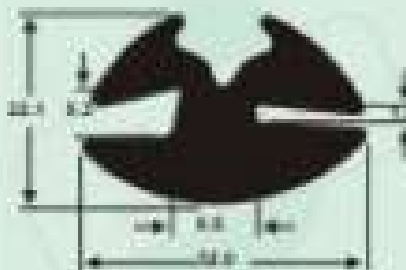
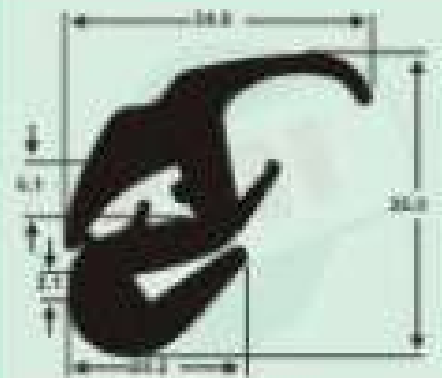
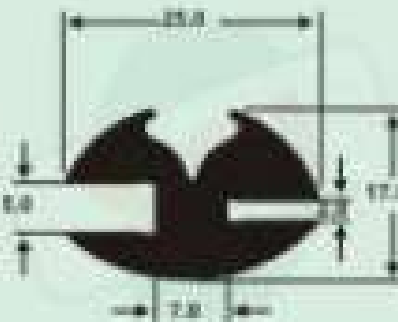
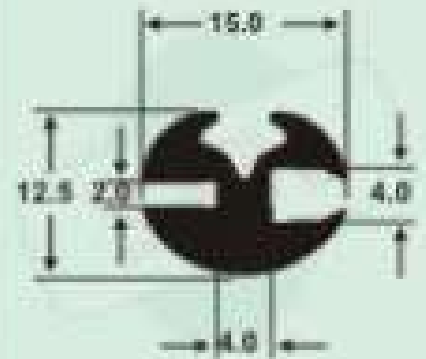
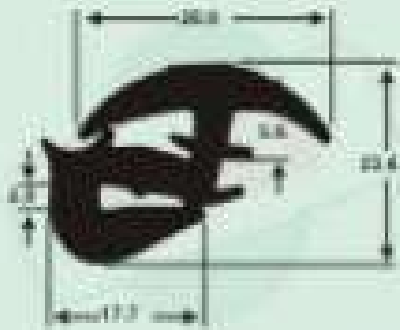

Bus Body Building Profiles

SAI

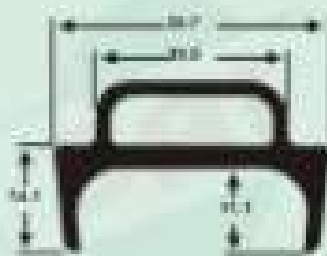
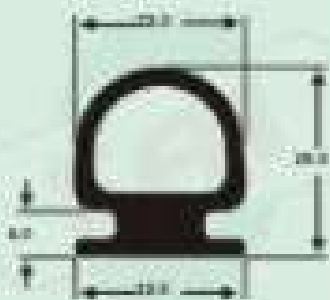
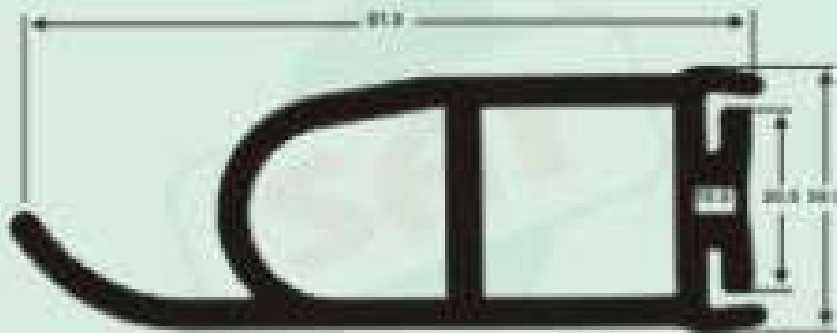
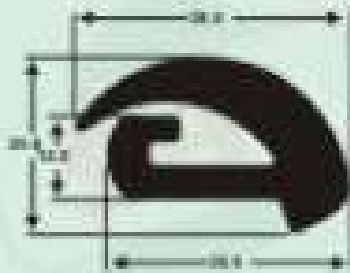
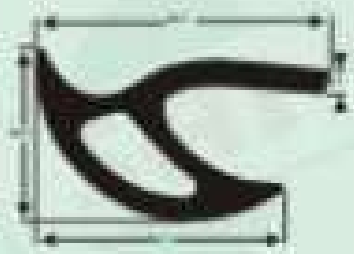
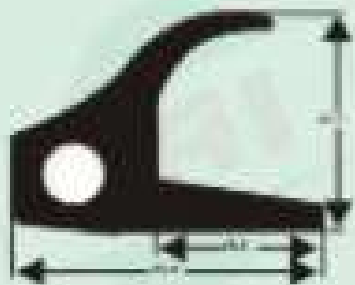

Bus Body Building Profiles

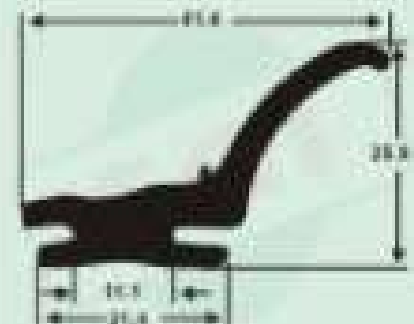
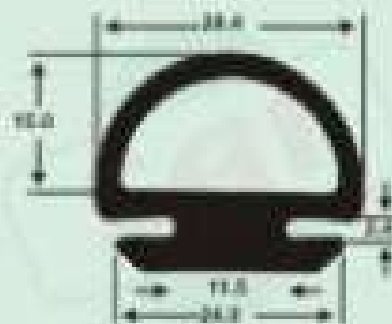

Bus Body Building Profiles

SAI

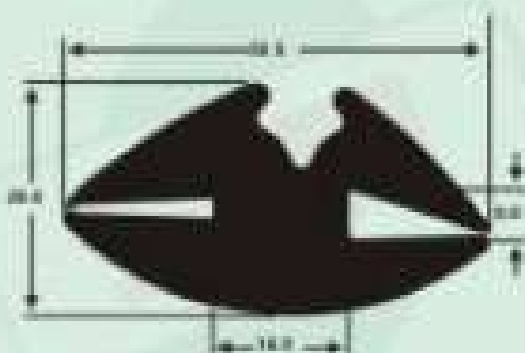
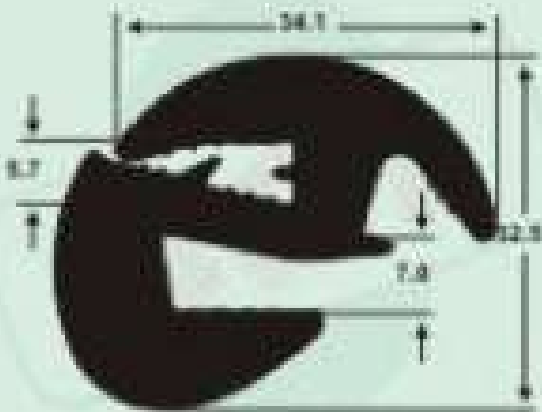
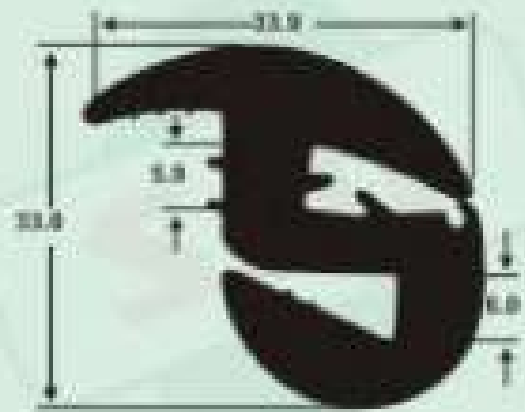
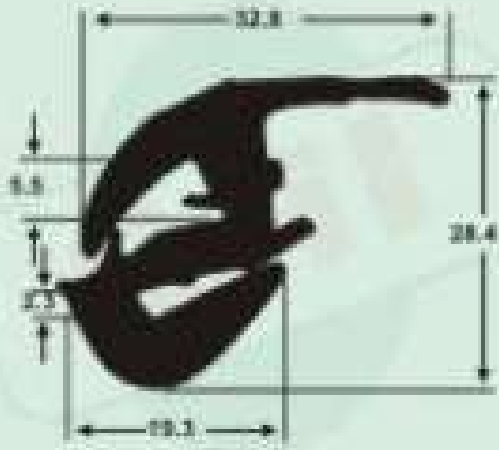

Bus Body Building Profiles

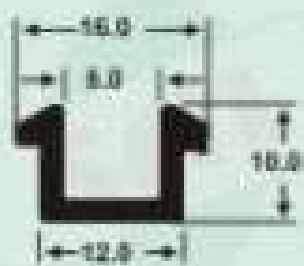
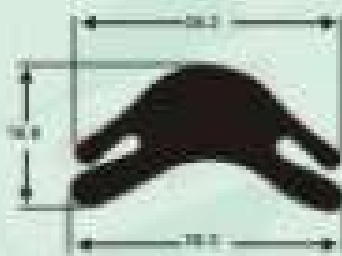
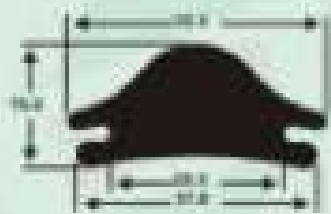

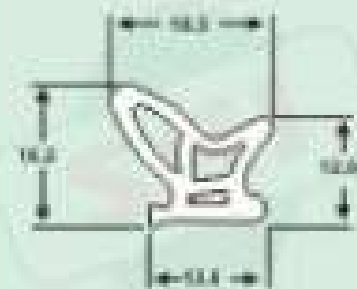
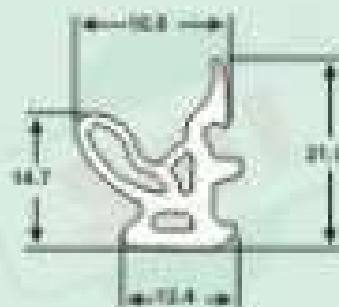
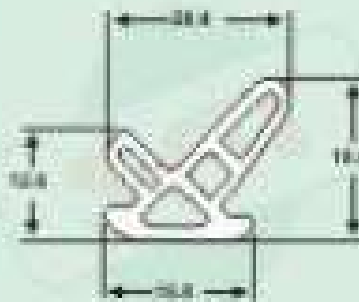
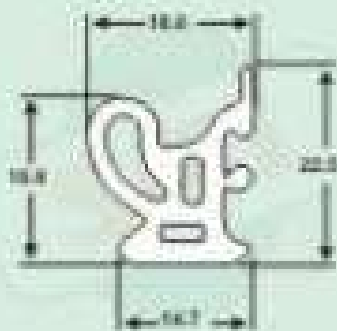
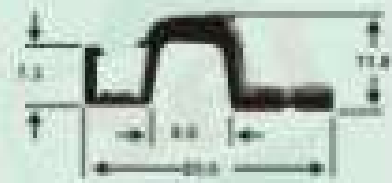
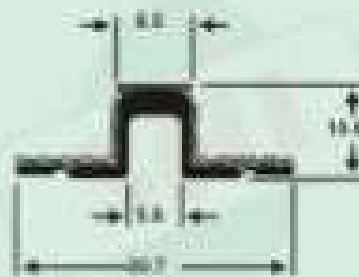
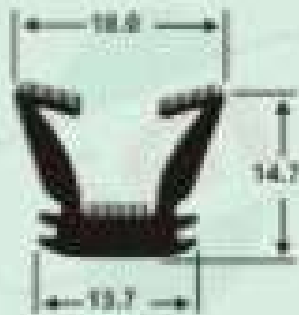
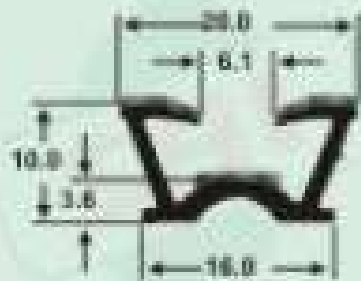

Pipe Clamping Profiles

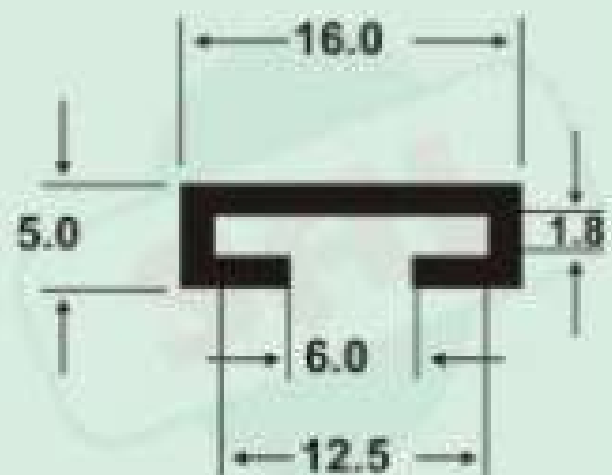
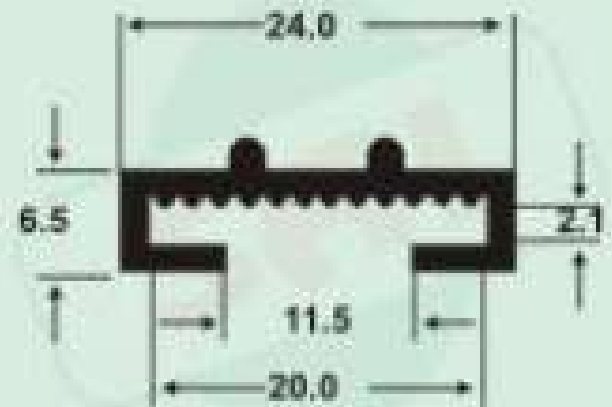
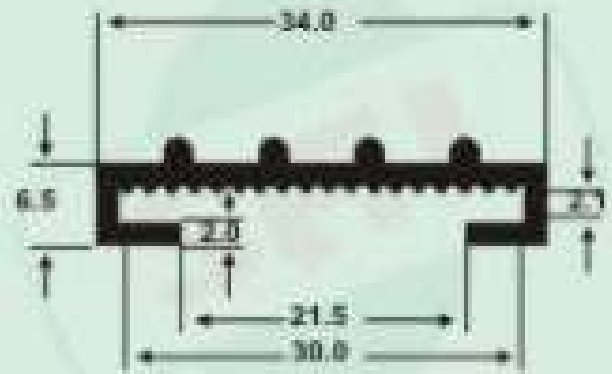
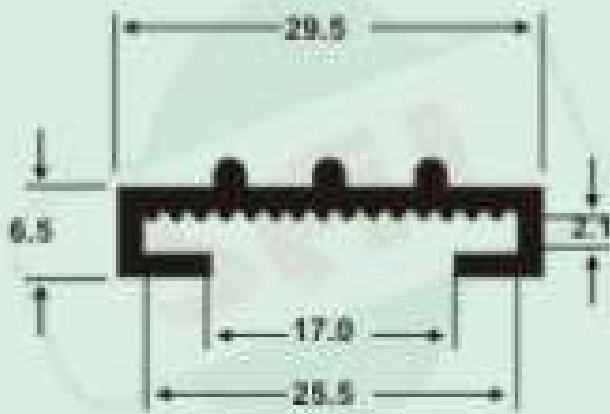



SHRIRAM INSTITUTE FOR INDUSTRIAL RESEARCH

(A unit of Shriram Scientific and Industrial Research Foundation)

ISO 9001

19, University Road, Delhi - 110007 (India)
An ISO - 9001, 14001 & OHSAS 18001 Certified Institute

Website : www.shriraminstitute.org
E-mail id : customercare@shriraminstitute.org

TEST CERTIFICATE

NO. : C1/0000058926

Issued To:
Client Code : S1191
SAL RUBBER
PLOT NO. 4 GALI NO. 4 RAGHUBIR
COLONY
SECTOR-2
BALLABGARH
FARDABAD
HARYANA-121004
Kind Attn: MR. ANIL GUPTA

Date: 19/09/2016
Job No.: 1609-3-141-2319
Booking No.: BO161101/3392
Booking Date: 20/08/2016
Customer Ref No.: -
Customer Ref Date: 19/09/2016

Sample Description :

ONE SAMPLE DESCRIBED AS RUBBER GLEZING, WAS RECEIVED.

The sampling was not carried out by the Representative of Shriram Institute for Industrial Research. The sample details provided in test certificate are based on declaration by the party.

S.No. Tests	Results	Protocol/Technique adopted
1. Hardness, Shore A	67	As per ASTM D 2240 - 13
2. Identification of major Polymer	Major Polymer is identified as EPDM (Ethene - Propene - diene - Rubber)	Detailed Chemical analysis & various Instrumentation techniques.

D.O.B :- 20-09-2016

D.O.C :- 19-10-2016

AUTHORISED SIGNATORY
EMPLOYEE CODE : 101591